

APPLY LUBRICANT TO ALL SEALS
PRIOR TO INSTALLATION.
DO NOT USE SILICONE TYPE LUBRICANTS.
FOR PROPER ARM MOUNTING SEE IS1505.

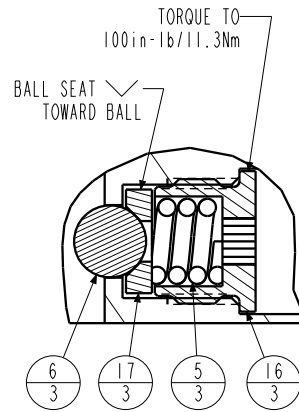
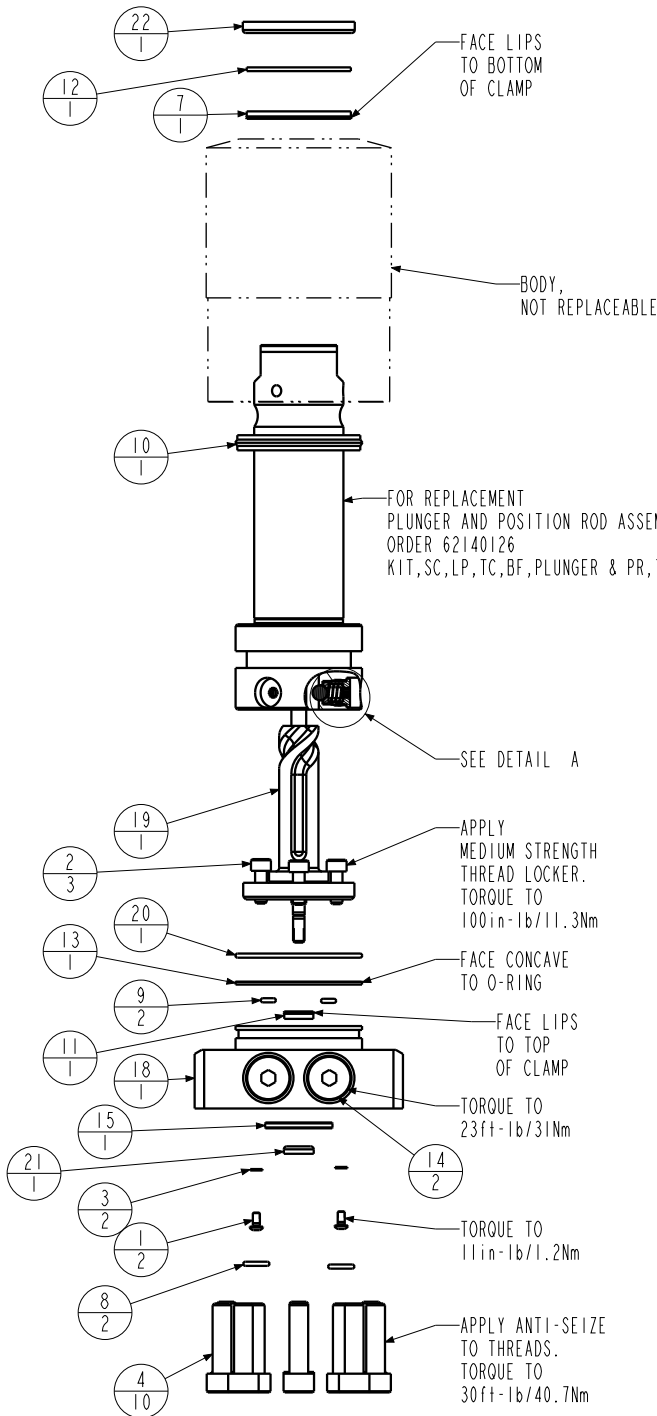

DETAIL A
SCALE 1.500

No.	QTY	PART No.	DESCRIPTION	Std. Seal Kit	FKM Seal Kit
N/A	N/A	IS1505	INSTRUCTION SHEET, ARM INSTALLATION		
N/A	N/A	6V711050	SEAL KIT, FKM		
N/A	N/A	60711050	SEAL KIT, STANDARD		
22	1	39V11051	WIPER, PRESS-IN, (1-1/2)	X	X
21	1	39V10029	WIPER, PRESS-IN, (1/4)	X	X
20	1	39H51002	O-RING, (-033)	X	39V51002
19	1	81592136	CAM, SC, LP, 7500/33KN, RH, LS, TC, PR		
18	1	81542112	BASE, SC, BF, LP, 33KN, PR		
17	3	81532108	SEAT, BALL, SC, LP, TC		
16	3	81532107	RETAINER, SC, LP, TC		
15	1	81500040	RING, LOCATOR, SC, LP, PR		
14	2	43068006	PLUG, 1/4 BSPP MALE		
13	1	39054017	BU RING, (-033)	X	39054023
12	1	39054016	BU RING, (1.5x.125x.063)	X	X
11	1	39052043	SEAL, LL, (1/4 X 1/8 X 1/8 X 1/2)	X	39V52043
10	1	39052030	SEAL, CROWN, 1-3/4x2-1/8x1/4	X	39V52030
9	2	39051041	O-RING, (-006)	X	39V51041
8	2	39050042	O-RING, (-011)	X	39051025
7	1	39011075	SEAL, LL, (1-1/2 X 1/8 X 1/8 1-3/4)	X	39V11075
6	3	23650004	BALL, TUNGSTEN-CARBIDE. 250		
5	3	23350066	SPRING, COMPRESSION		
4	10	21500305	SHCS, M8 X 1.25-6G X 30MM		
3	2	21500200	WASHER		
2	3	21500031	SHCS, M5 X 0.8 X 14, ALY		
1	2	21500019	SCREW, CAP, BTNH, M3 X 6, ALY		

PARTS LIST



VEKTEK, INC.
1334 E. SIXTH AVE. P.O. BOX 625
EMPORIA, KS. 66801 U.S.A.

ASSEMBLIES AFFECTED

41423326PR

41423326PRF

PARTS LIST, ASSY, SC, LP, TC, BF, 33KN, DA, RH, LS, PR

SIZE
A

MPLV7257

REV
C

SHEET 1 OF 1

C	5762	RELEASE	JDW	07/18/25
REV	IN ACCORDANCE WITH ECN	EFFECTIVE DATE	REVISED BY	DATE
DRW BY:	JDW	DRAWING STATUS: Released		
DATE:	03/04/19	PRODUCTION APPROVED FOR RELEASED STATUS ONLY		

